

Installation Manual

C-2987
ARNOTT REAR COIL SPRING CONVERSION KIT
W/EBM
HUMMER H2 (GMT913)

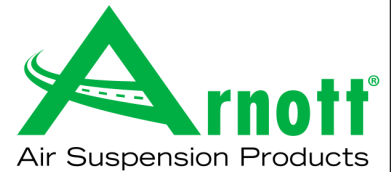

Congratulations on your purchase of an Arnett® air suspension product. We at Arnett Incorporated are proud to offer a high quality product at the industry's most competitive pricing. Thank you for your confidence in us and our product.

Proper installation is essential to experience and appreciate the benefits of this system. Please take a moment to review these installation instructions before you begin to install these components on your vehicle. The removal and installation of air suspension products should only be performed by a fully qualified, ASE Certified, professional.

It is equally important to be aware of all necessary safety measures while installing your new Air Suspension System. This includes proper lifting and immobilizing of the vehicle and isolation of any stored energy to prevent personal injury or property damage.

"Engineered to Ride, Built to Last®"



WARNING: *The air suspension system is under pressure (up to 10 bar, or 150 lbf/in). Verify pressure has been relieved and disconnect power to the air suspension system prior to disassembly. Do not allow dirt or grease to enter the system. Always wear standard hand, ear, and eye protection when servicing the air suspension system.*

Arnett® is committed to the quality of its products. If you have a question or problem with any Arnett product, please contact Arnett by calling **800-251-8993** during normal business hours or email techassistance@arnottinc.com. (In the EU please call +31 (0)73 7850 580 or email info@arnotteurope.com).

GENERAL INFORMATION:

Reading this manual signifies your agreement to the terms of the general release, waiver of liability, and hold harmless agreement, the full text of which is available at www.arnottinc.com.

- Not to be stored below 5°F (-15°C) or above 122°F (50°C).
- Avoid damage to air lines and cables.
- Removal and installation is only to be performed by fully qualified personnel.
- Use car manufacturer's diagnostic software.

CAUTION: *Damage to the vehicle and air suspension system can be incurred if work is carried out in a manner other than specified in the instructions or in a different sequence.*



To avoid the possibility of short circuits while working with electric components consult your owner's manual on how to disconnect your battery.



Consult your vehicle owner's manual, service manual, or car dealer for the correct jacking points on your vehicle and for additional care, safety and maintenance instructions. Under no circumstances should any work be completed underneath the vehicle if it is not adequately supported, as serious injuries and death can occur.

REAR AIR SHOCK/COIL SPRING REMOVAL

1. SET STEERING TO STRAIGHT.
2. RAISE VEHICLE.
3. REMOVE THE REAR WHEELS. (FIGURE 1)



FIGURE 1

5. DISCONNECT THE AIR LINE FROM THE QUICK CONNECT ON THE AIR SPRING. (FIGURES 2, 3)



FIGURE 2



FIGURE 3

4. DEFLATE THE AIR SPRING. (FIGURE 4)



FIGURE 4

6. LOOSEN AND REMOVE THE LOWER SHOCK MOUNTING NUTS. (FIGURES 5)



FIGURE 5

7. SUPPORT THE AXLE TO RELIEVE PRESSURE FROM THE SHOCKS MOUNTING POINTS. REMOVE THE LOWER SHOCK MOUNTING BOLTS. (FIGURE 6)



FIGURE 6

8. REMOVE THE BOLTS AND RIDE HEIGHT SENSOR LINKAGE FROM THE UPPER CONTROL ARMS. (FIGURES 7, 8)



FIGURE 7



FIGURE 8

9. REMOVE THE BOLT AND BRACKET HOLDING THE BRAKE LINE TO THE REAR DIFFERENTIAL. (FIGURES 9, 10)



FIGURE 9



FIGURE 10

10. REMOVE THE NUTS ON THE UPPER SWAY BAR END LINKS. (FIGURE 11)



FIGURE 11)

11. USING A JACK OR OTHER SUITABLE DEVICE, SUPPORT THE AXLE TO RELEASE PRESSURE FROM THE SWAY BAR END LINKS. REMOVE THE SWAY BAR END LINK BOLTS. (FIGURES 12, 13)



FIGURE 12



FIGURE 13

12. REMOVE THE AIR SPRING ASSEMBLY AS WELL AS THE PISTON SUPPORT FROM THE AXLE HOUSING. (FIGURE 14, 15, 16)



FIGURE 14



FIGURE 15



FIGURE 16

REAR COIL SPRING INSTALLATION



Tighten all nuts and bolts to manufacturer's specifications during the installation process.

1. INSTALL THE REAR COIL CONVERSION IN THE REVERSE ORDER OF REMOVAL.

NOTE:

Secure the air lines in suitable locations as they are not used for this kit.

2. INSTALLATION COMPLETE.

ELECTRONIC BYPASS MODULE INSTALLATION

1. LOCATE THE VEHICLE'S DATA LINKAGE CONNECTOR (DLC) UNDER THE LEFT SIDE OF THE DASHBOARD AND UNFASTEN FOR ACCESS. (FIGURE 17)

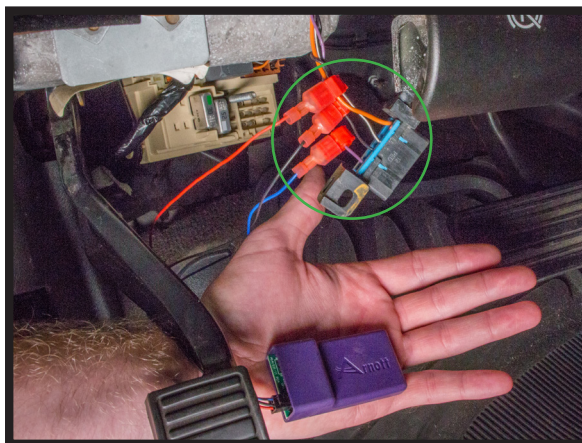
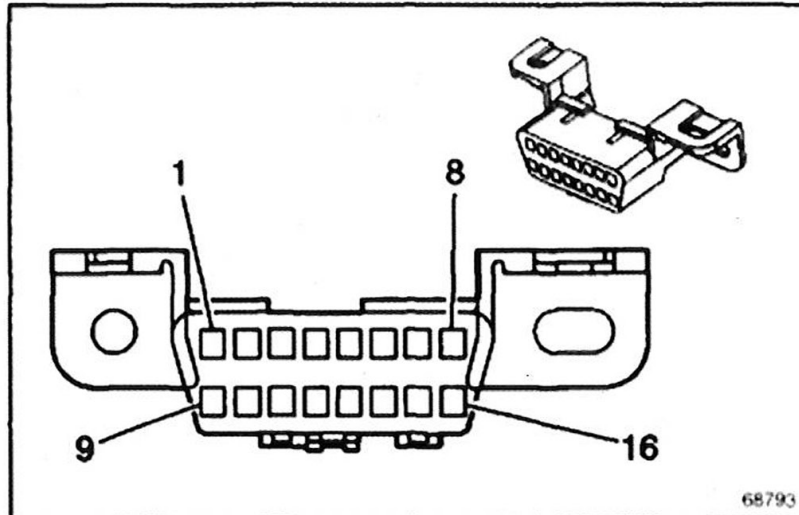

FIGURE 17

2. USING THE DIAGRAM FOUND ON THE FOLLOWING PAGE, CONNECT THE ELECTRONIC BYPASS MODULE MAKING SURE TO SECURE THE MODULE IN A SUITABLE LOCATION FREE FROM MOVING PARTS. (FIGURE 18)

Data Link Connector (DLC)



Connector Part Information		<ul style="list-style-type: none"> • 12110250 • 16-Way F Metri-Pack 150 Series (BK) 	
Pin	Wire Color	Circuit No.	Function
1	—	—	Not Used
2	PU	1132	DLC Class 2 Serial Data
3	—	—	Not Used
4	BK	1050	Ground
5	BK/WH	1851	Ground
6-15	—	—	Not Used
16	OG	640	Battery Positive Voltage

Utilizing the supplied electrical splices, splice into the wires as directed below.

DLC-----Arnett EBM

Pin 2 ---- Blue

Pin 4 ---- Black

Pin 16 ---- Red

FIGURE 18

4. INSTALLATION COMPLETE.