

# MAZDA

<b>GB</b>	<b>UNDERGUARD</b> Installation Instruction
<b>D</b>	<b>UNTERBODENSCHUTZ</b> Einbauanleitung
<b>E</b>	<b>PROTECCIYN DE LOS BAJOS</b> Instrucciones de montaje
<b>F</b>	<b>PROTECTION DU DESSOUS DE CAISSE</b> Instructions de montage
<b>I</b>	<b>PROTEZIONE SOTTO SCOCCA</b> Istruzioni di montaggio
<b>P</b>	<b>BETUMINOSO</b> Instruções de montagem
<b>NL</b>	<b>BODEMBESCHERMER</b> Inbouw-instructie
<b>DK</b>	<b>UNDERVOGNSBESKYTTELSE</b> Monteringsvejledning

<b>N</b>	<b>UNDERSTELLBESKYTTELSE</b> Monteringsvejledning
<b>S</b>	<b>UNDERREDSBEHANDLING</b> Monteringsanvisning
<b>SF</b>	<b>POHJAMASSAUS</b> Asennusohje
<b>CZ</b>	<b>OCHRANA PODVOZKU PROTI KOROZI</b> Návod k montáži
<b>H</b>	<b>ALVÉZVÍDELEM</b> Beszerelési utasítás
<b>PL</b>	<b>OCHRONA PODWOZIA</b> Instrukcja zabudowy
<b>GR</b>	<b>ΠΡΟΣΤΑΤΕΥΤΙΚΗ ΠΛΑΚΑ ΚΑΤΩ ΜΕΡΟΥΣ</b> <b>ΑΜΑΞΩΜΑΤΟΣ</b> Οδηγίες τοποθέτησης
<b>RUS</b>	<b>ЗАЩИТА ШАССИ</b> инструкция по установке

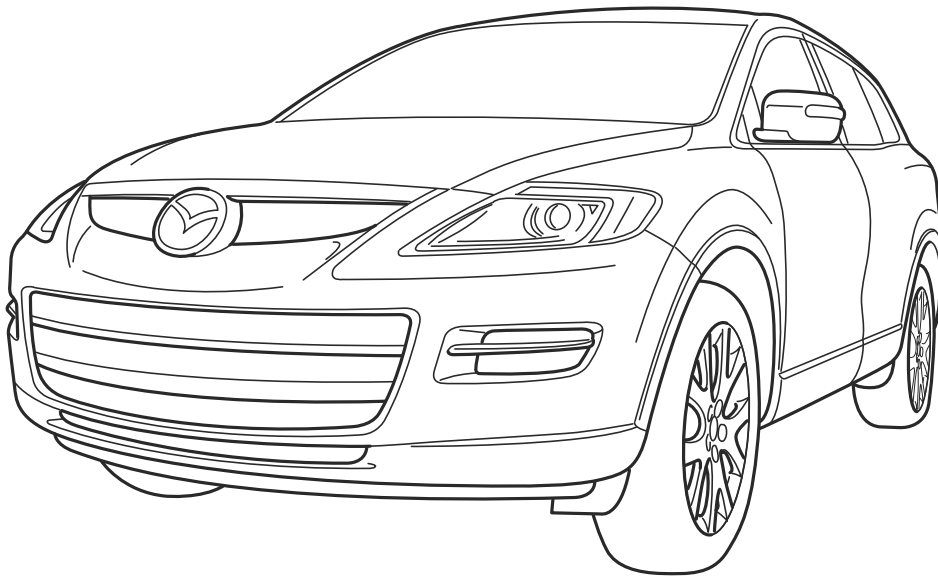

**CX-9**

Part Number: 8300-77-011

Date: 08-06-2009

© Copyright MAZDA

Sheet 1 of 8

Expert Fitment Required  
Montage durch Fachwerkstatt erforderlich  
Montaje sólo por el concesionario  
Montage par spécialiste nécessaire  
E' necessario in officina specializzata  
Especialista em montagem requerido  
Montage door vakman nodig  
Montage ved professionelt værksted påkrævet  
Nødvendig med montering fra fagvejværksted  
Verkstadsmontage erfordras  
Asennus tarpeen merkkikorjaamossa  
Montáž ve specializované dílně nutná  
A szereléshez szakműhely kell  
Konieczny montaż przez warsztat specjalistyczny  
Να τοποθεί απο συνεργείο  
Необходима установка специалистами



- (GB) Location/Position Arrow
- (D) Positionspfeil
- (E) Flecha de posición
- (F) Flèche de Position
- (I) Freccia di posizione
- (P) Flexa de posição
- (NL) Lokatie/Positie pijl
- (DK) Lokaliseringspil
- (N) Posisjonspil
- (S) Positionpil
- (SF) Paikannuoli
- (CZ) Šipka na pozici
- (H) Helyzetjelző nyíl
- (PL) Strzałka położenia
- (GR) Βέλος θέσης
- (RUS) Позиция

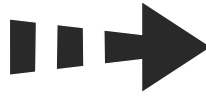

- (GB) Movement Arrow
- (D) Bewegungspfeil
- (E) Flecha de movimiento
- (F) Flèche indiquant sens du vouvement
- (I) Freccia di movimentov
- (P) Flexa de movimento
- (NL) Richtingspijl
- (DK) Bevægelsespil
- (N) Bevegelsespil
- (S) Rörelsepil
- (SF) Liikesuuntanuoli
- (CZ) Šipka pohybu
- (H) Mozgásirányjelző nyíl
- (PL) Strzałka kierunku ruchu
- (GR) Βέλος κίνησης
- (RUS) Стрелка по направлению

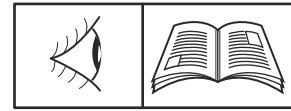

- (GB) See Workshop Manual
- (D) Siehe Werkstatthandbuch
- (E) Ver manual de taller
- (F) Voir Manuel d'atelier
- (I) Vedere manuale officina
- (P) Cf. o manual da oficina
- (NL) Zie werkplaatshandboek
- (DK) Se værkstedshåndbog
- (N) Se verkstedshenboka
- (S) Se verkstadshandboken
- (SF) Katso korjaamon käsikirjasta
- (CZ) Viz dílenskou příručku
- (H) Lásd a Műhely-kézikönyvben
- (PL) Patrz podręcznik warsztatowy
- (GR) λέτε Εγχειρίδιο Συνεργείου
- (RUS) Смотри руководство для мастерской

**A**

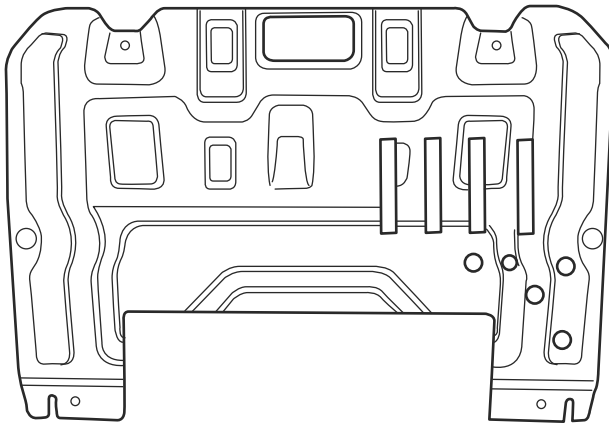

1x

Subject to alteration without notice  
 Technische Änderungen vorbehalten  
 Reservadas modificaciones técnicas  
 Sous réserve de modifications techniques  
 Con riserva di apportare modifiche tecniche  
 Reservamo-nos o direito a alterações técnicas  
 Technische wijzigingen voorbehouden  
 Med forbehold for tekniske indringer  
 Tekniske forendringer forbeholdes  
 Med reservation för tekniska ändringar  
 Tekniset muutokset pidätetään  
 Technické zmeny vyhrazeny  
 A változtatások technika jogát fenntartjuk  
 Zmiany techniczne zastrzeżone  
 Επιφυλασσόμεθα για αλλαγές  
 Можно изменять без уведомления

**B**



1x

**C**



1x

**D**

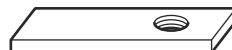

2x

**E**

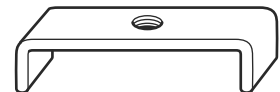

2x

**F**



2x

**G**

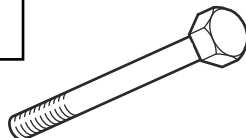

2x

**H**



4x

**I**

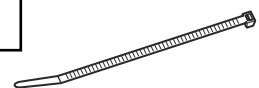

2x

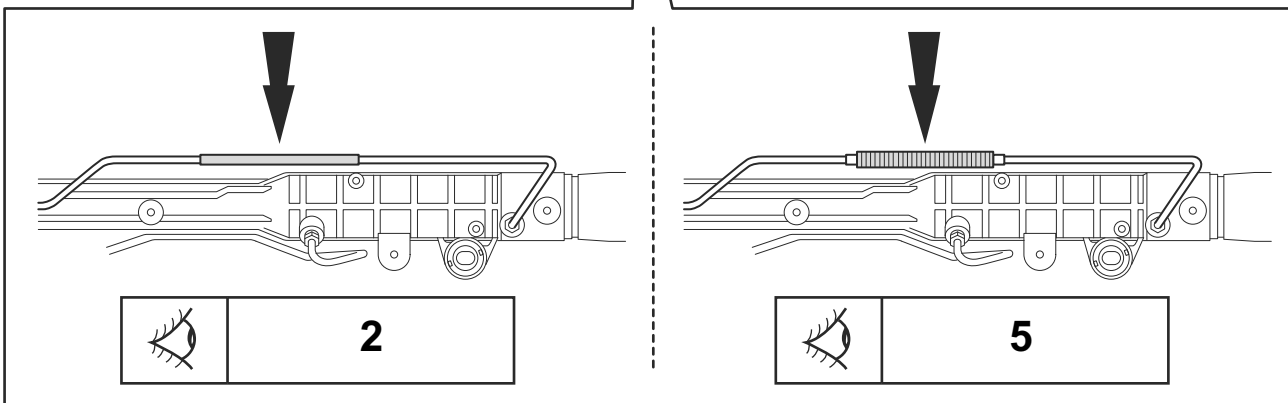
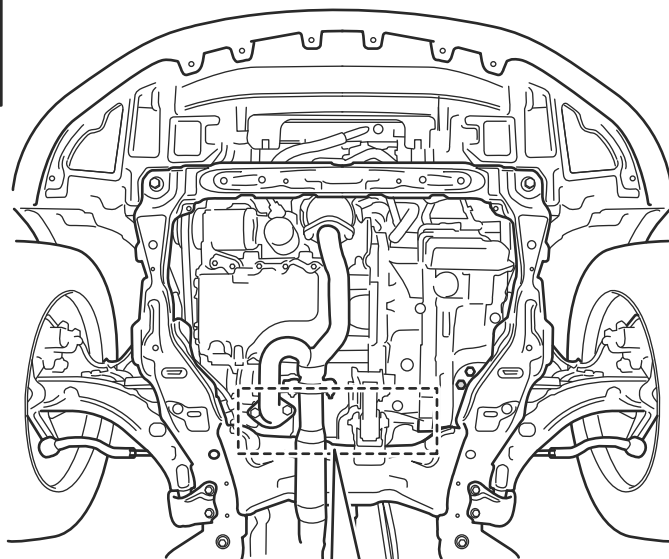

1

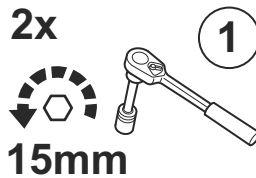
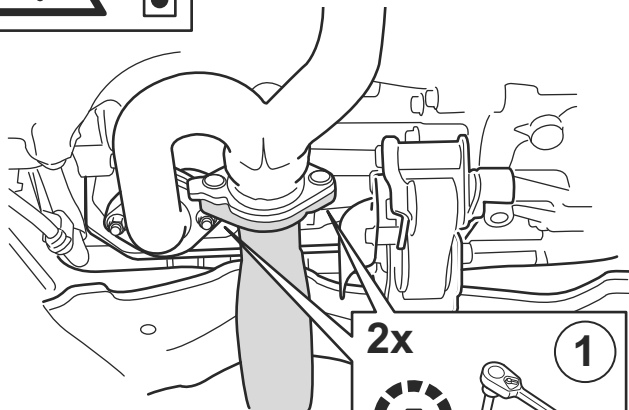

2

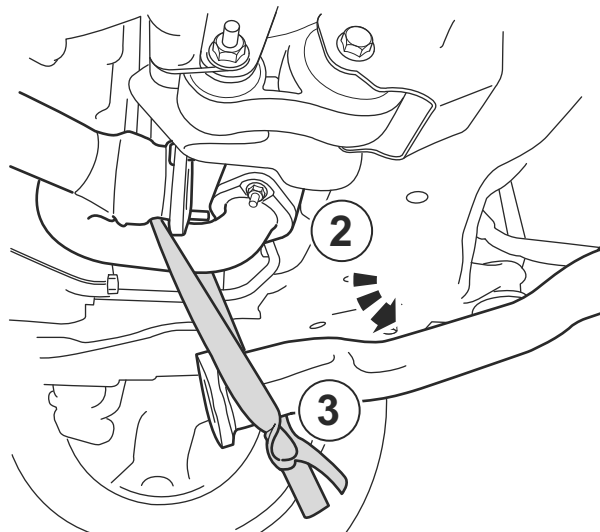

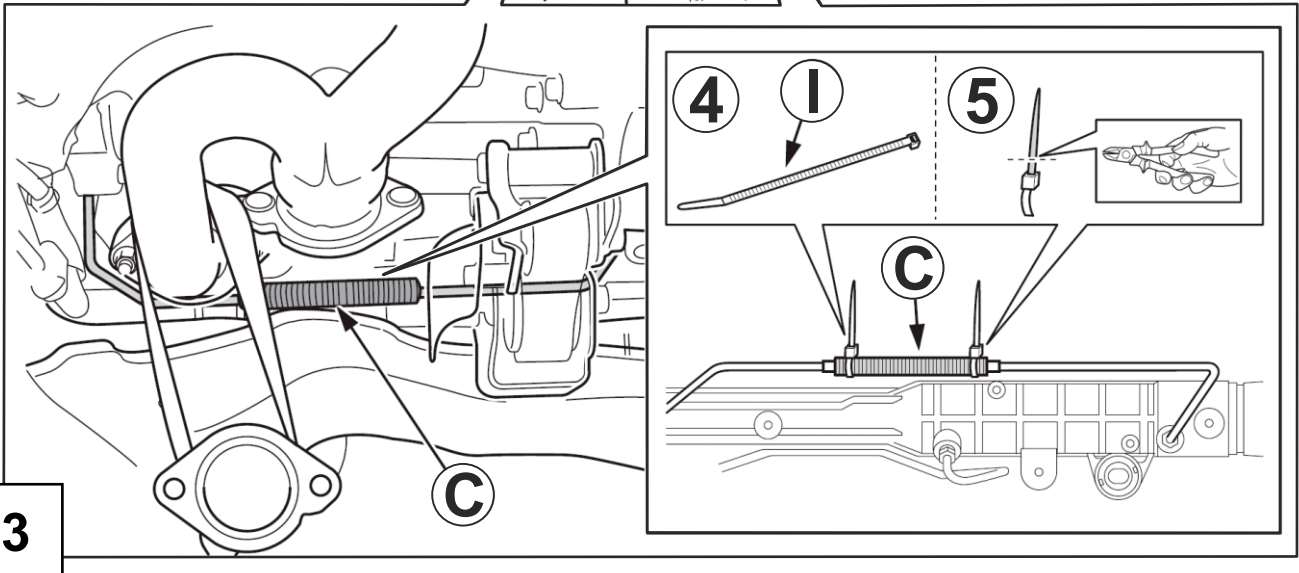
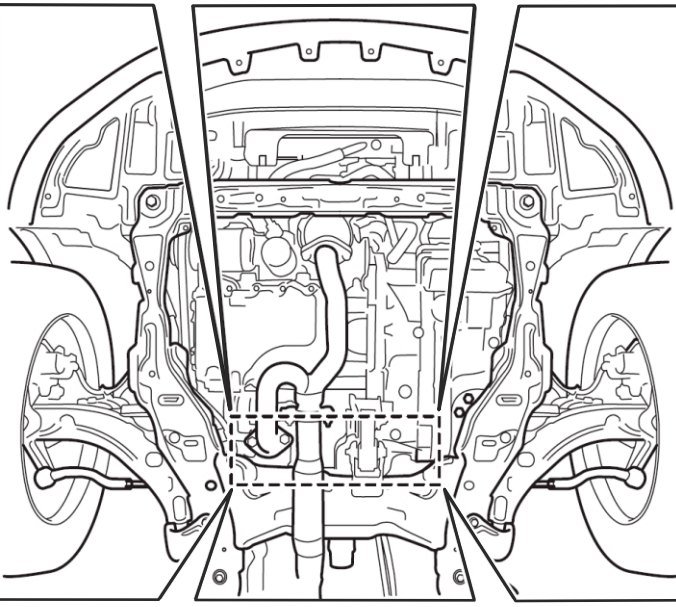
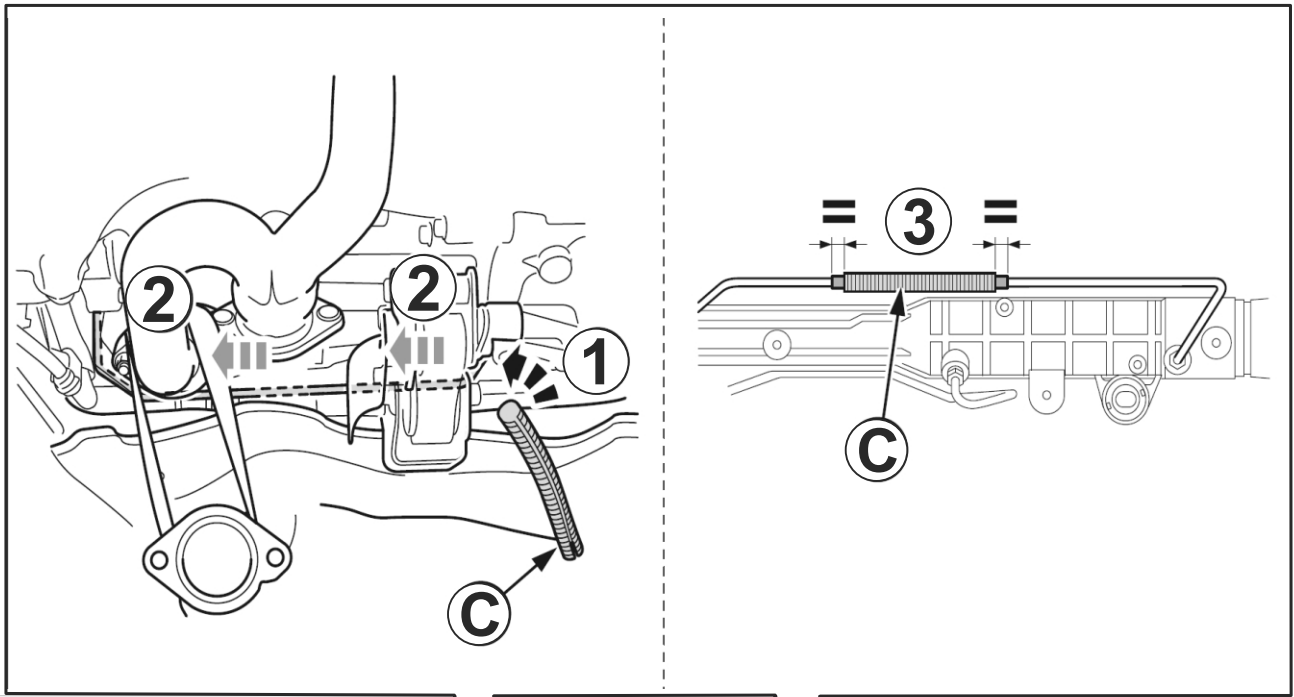

3

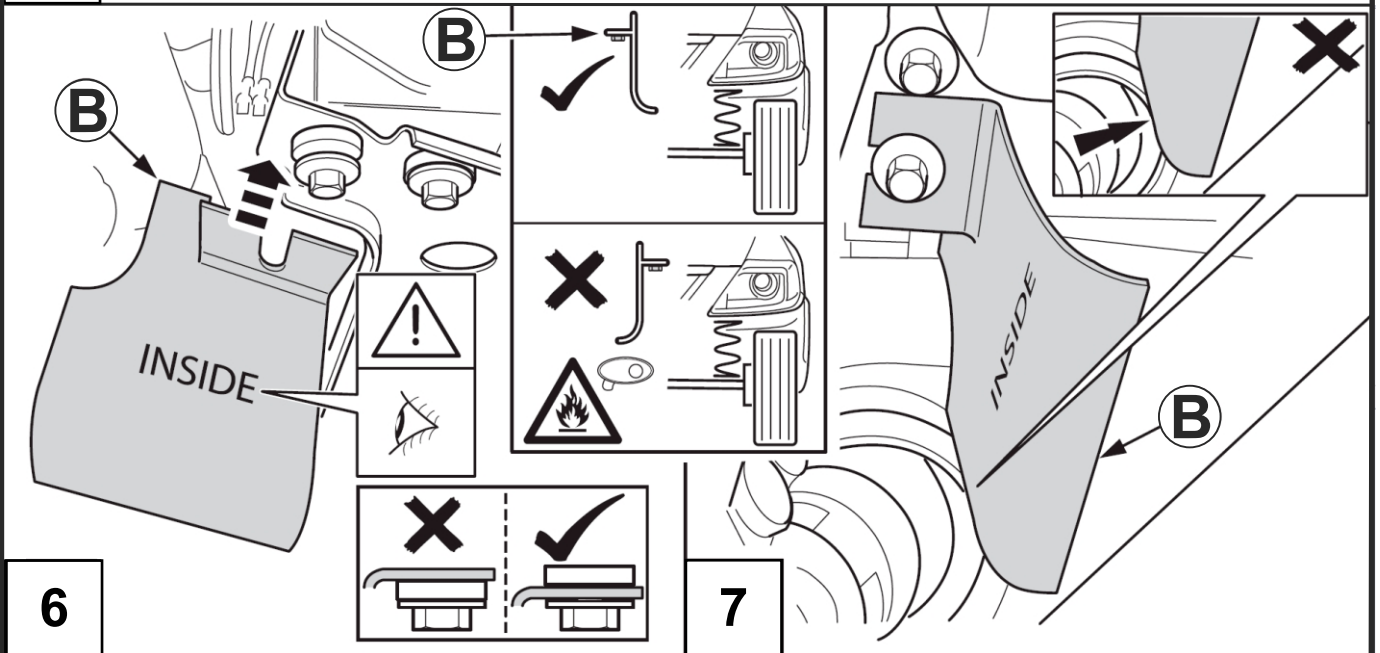
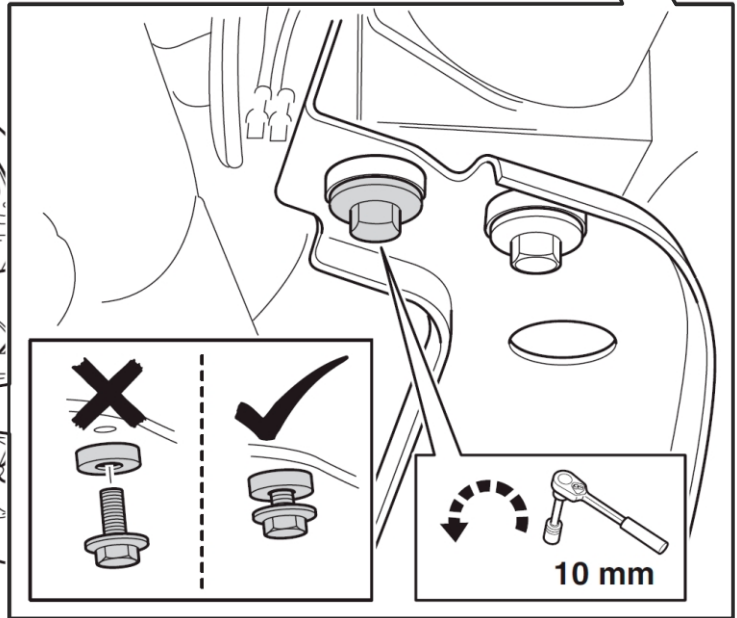
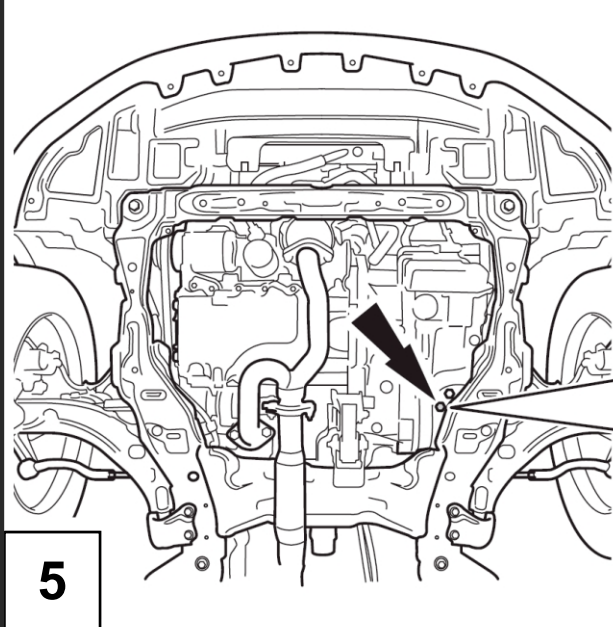
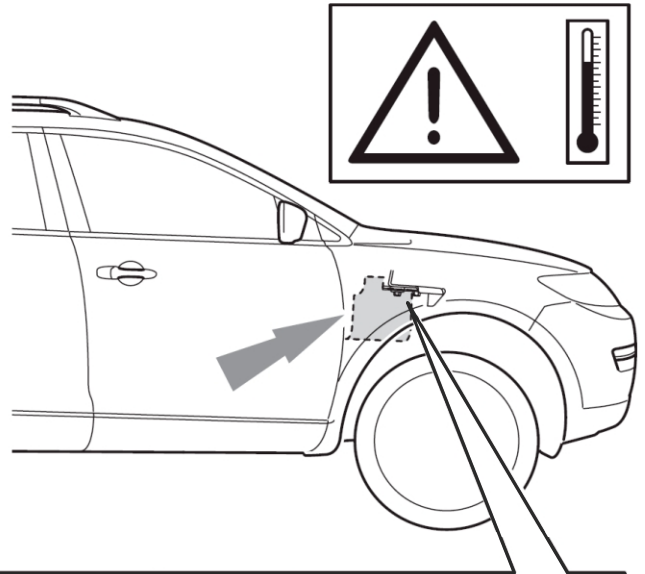
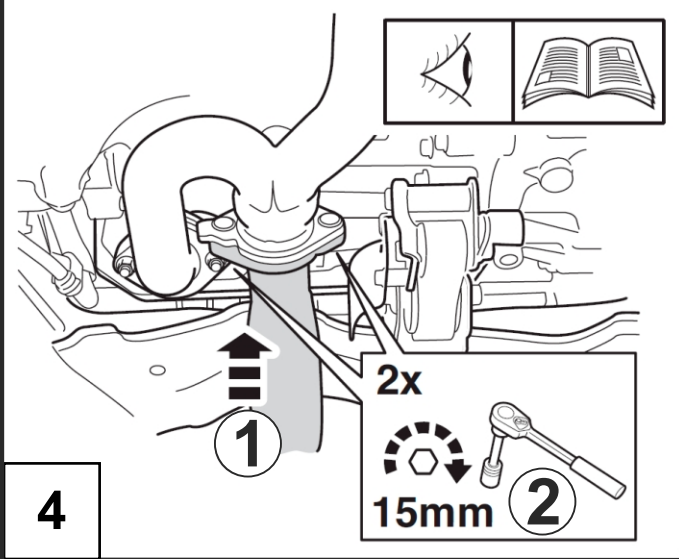

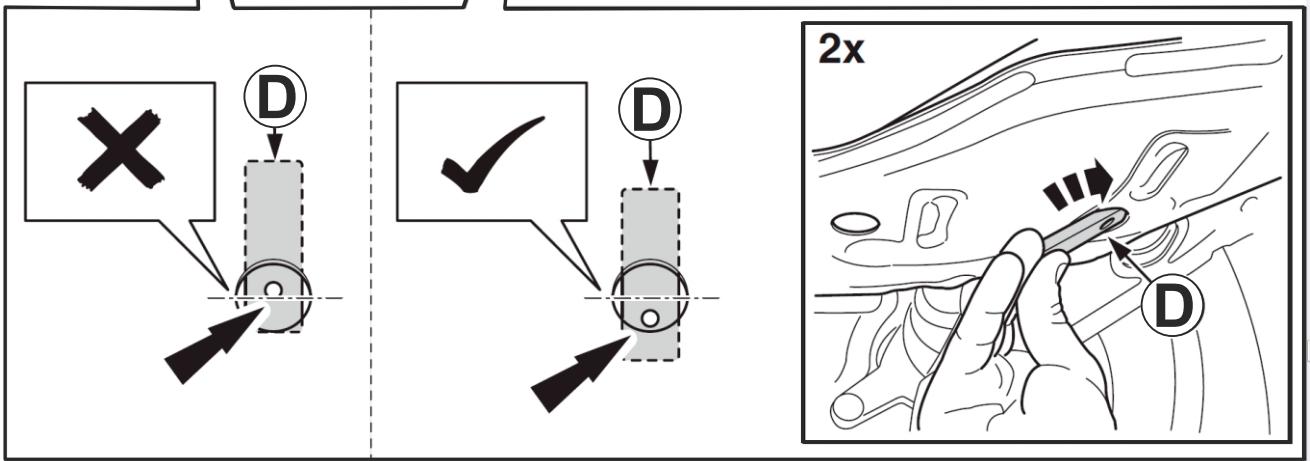
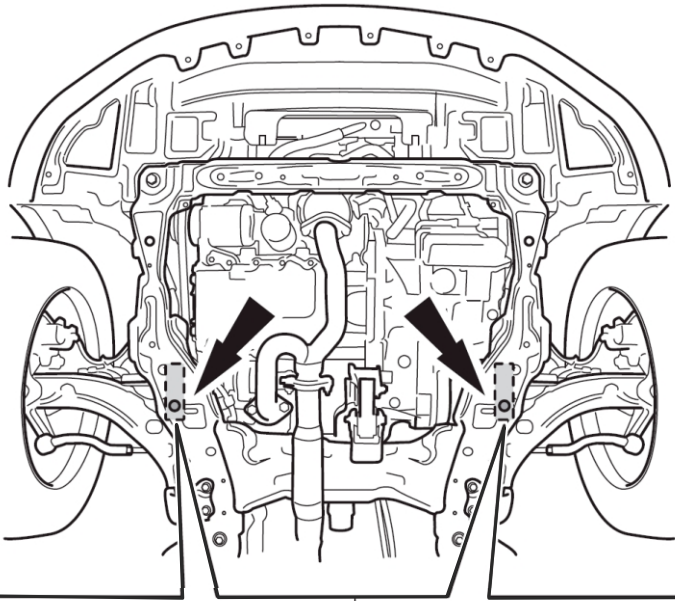
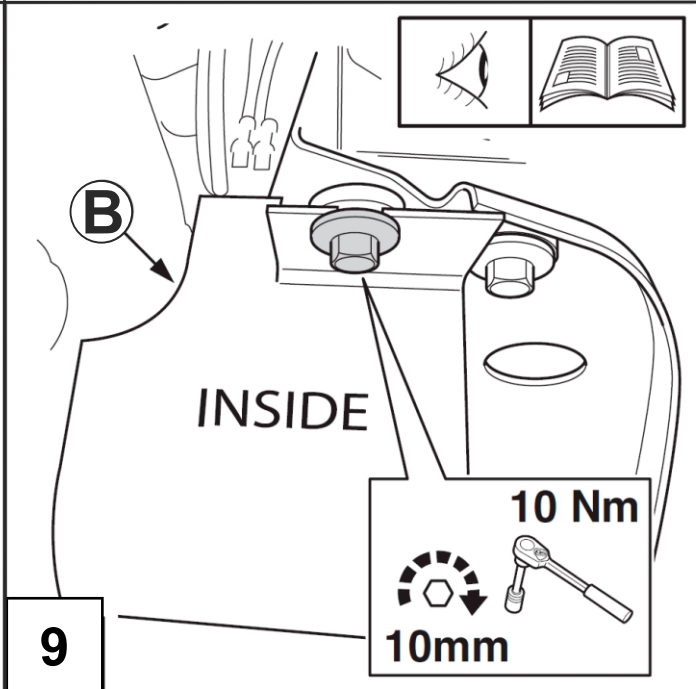
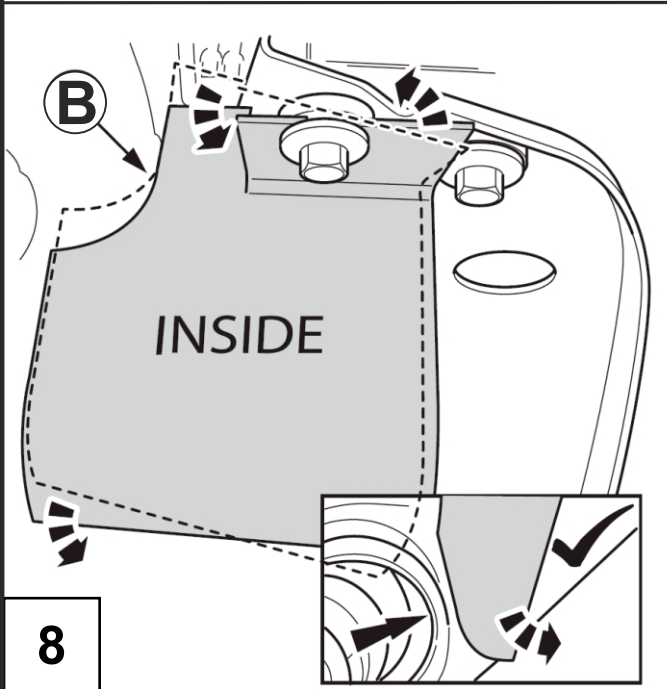

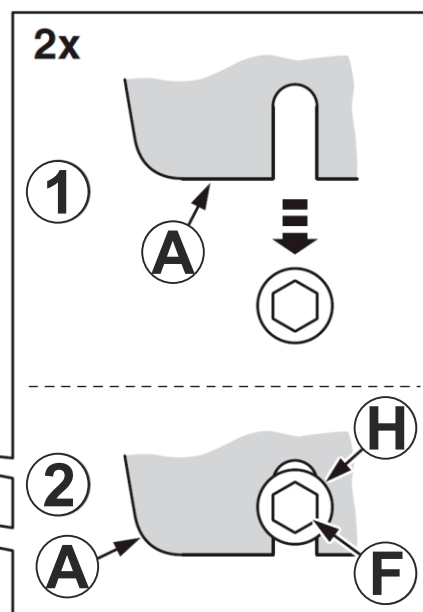
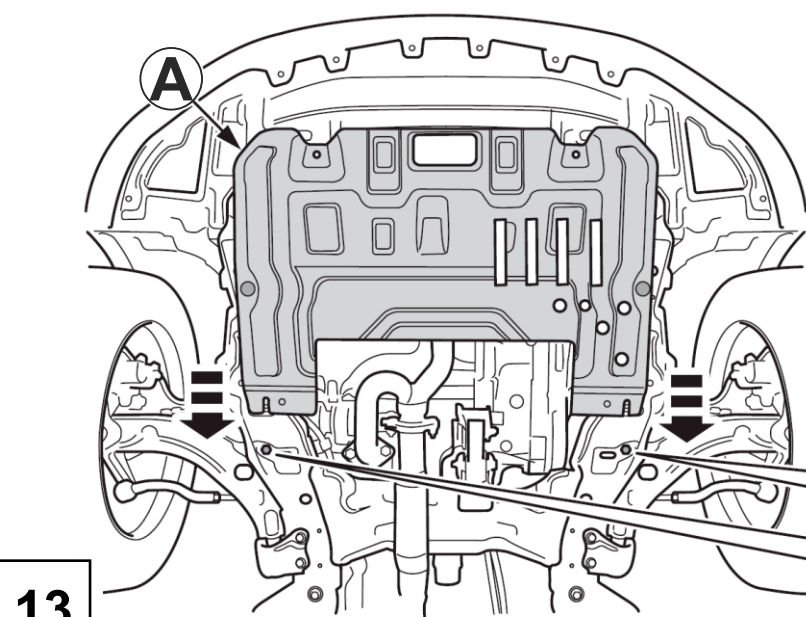
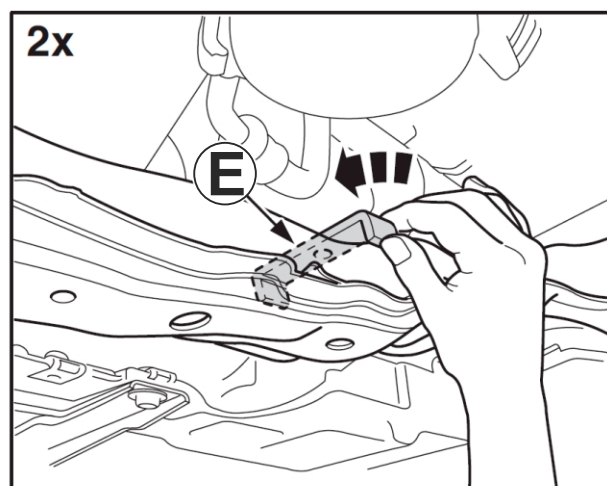
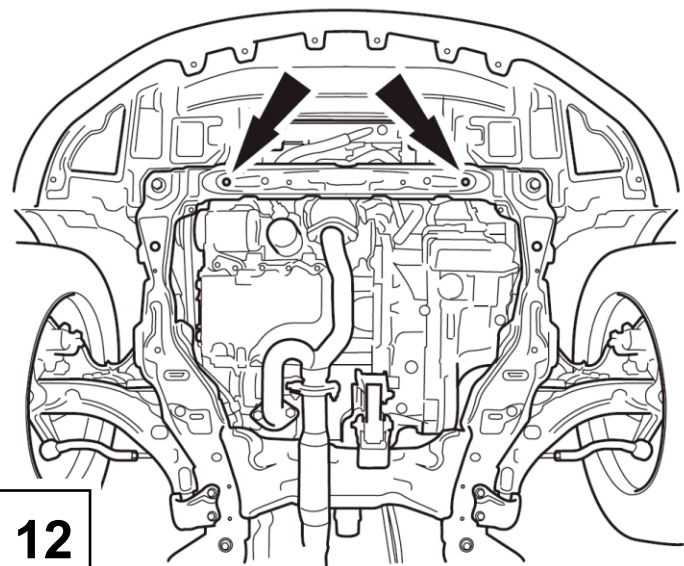
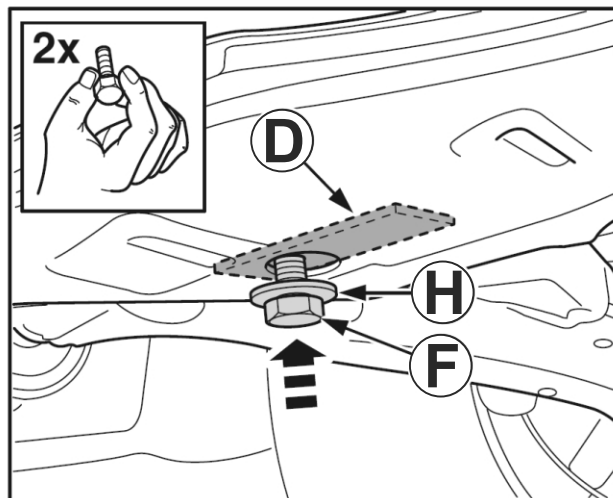
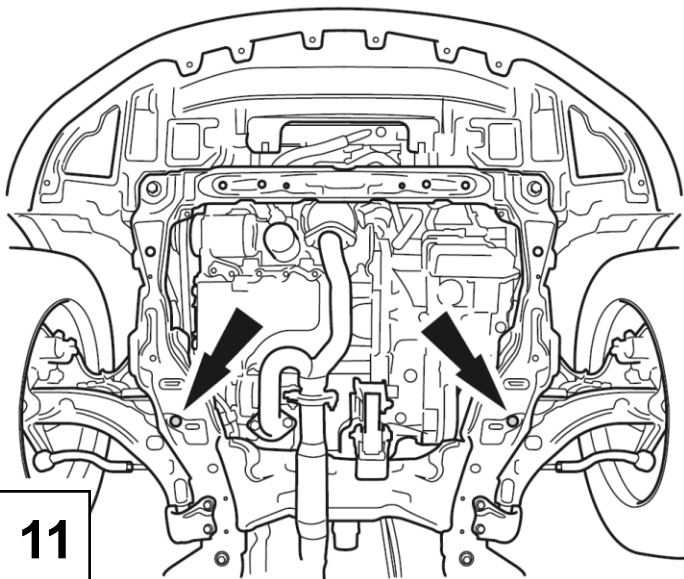

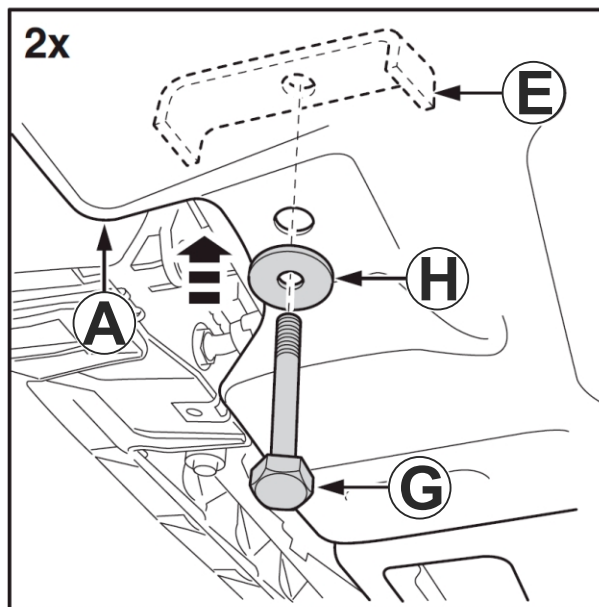
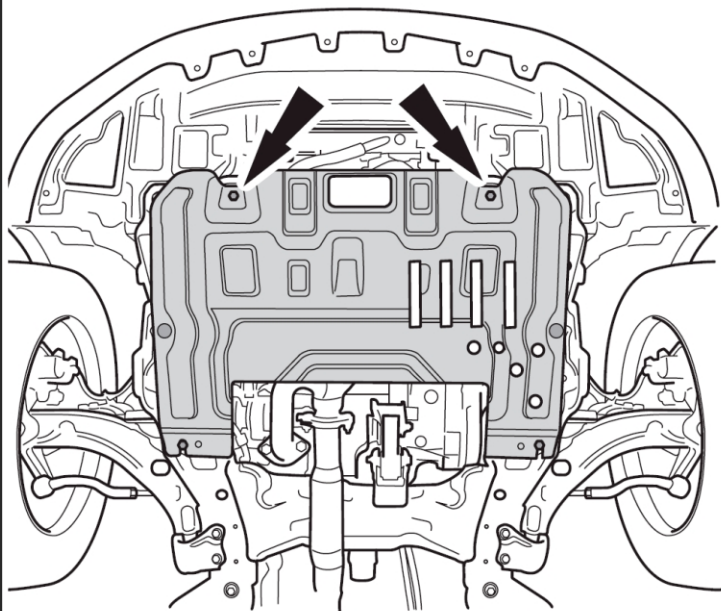

**14**

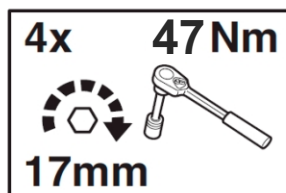
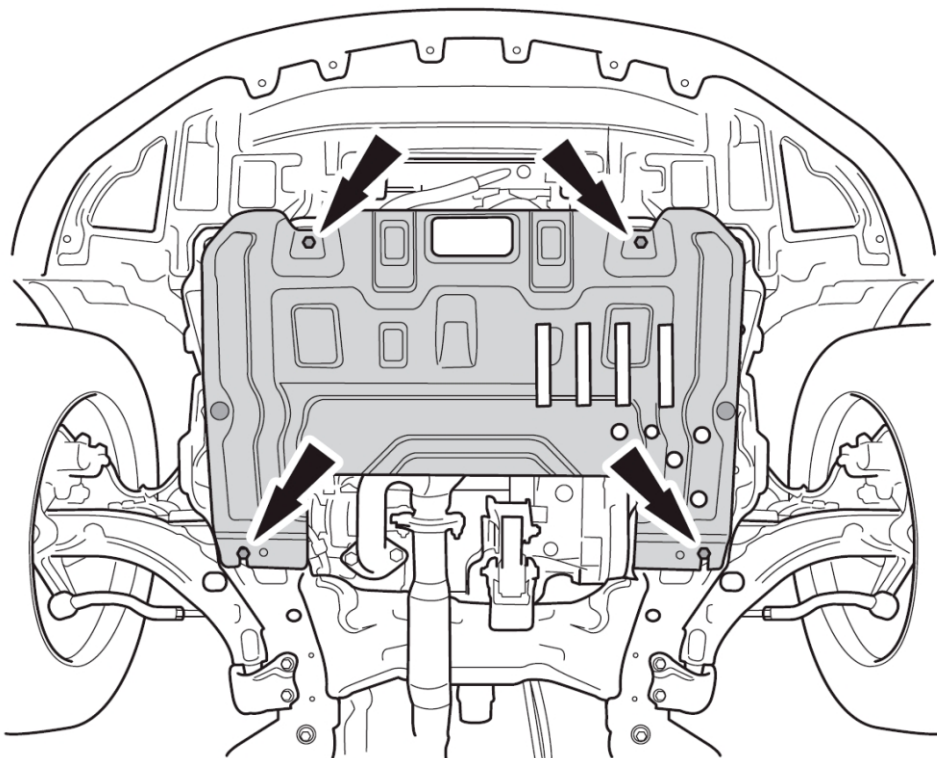

**15**